

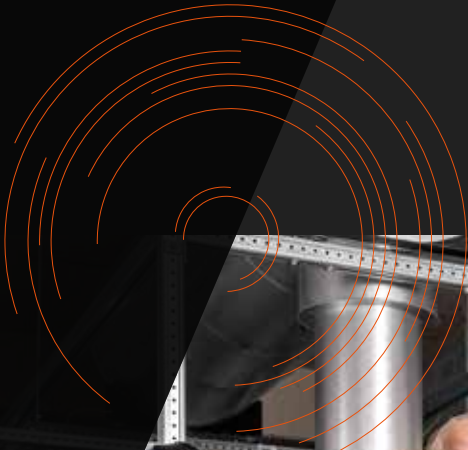

Dynamic UPS Solutions

Uninterruptible, continuous, and conditioned power for critical applications and processes

hitec-ups.com



**CONTINUOUS POWER
IN YOUR CONTROL**



We Are HITEC Power Protection

Continuous power in your control

HITEC Power Protection operates from its head office and manufacturing facility located in Almelo, the Netherlands. With regional support centers in the USA and Asia Pacific, and subsidiary companies in the United Kingdom, Germany, Brazil, Spain, Japan, Malaysia, China, and Taiwan, HITEC provides worldwide coverage. The company's global footprint is further enhanced by a certified network of top-tier distributors, agents, and representatives that ensure HITEC customers receive outstanding service and support regardless of location.

what we are proud of

500+

CUSTOMERS SUPPORTED

2200+

SYSTEMS INSTALLED

30+

OFFICIAL PARTNERS

60

COUNTRIES SERVED

3600

LARGEST UNIT KVA

14

REGIONAL COMPANY LOCATIONS

3300+

MVA POWER DELIVERED



Our Promise

“Our passion is supplying quality power to protect the world's most critical applications”

As the world's population increases, its reliance upon communications, connectivity, manufacturing, and automation will stretch power grids to their limit. The resulting growth of urban expansion and power dependency will create significant risks that could lead to unscheduled utility outages. Such dramatic events can adversely affect essential facilities such as hospitals, airports, stock exchanges, data centers, and industrial manufacturing processes.

HITEC Power Protection's mission is to support the most vital services by delivering safe, reliable, conditioned, and continuous power. In this manner HITEC is ensuring the uninterrupted operation of its customers' essential services and business-critical applications with the most innovative UPS solutions available.

We understand your market

Trusted by more than 500 customers in 60 countries

HITEC has worked with companies, large and small, around the globe and within almost every business sector. For every situation our mission is the same: to reduce risk, increase performance, and support the customer's business with the continuous power of our Dynamic UPS solutions. HITEC's unrivaled market experience enables it to fully appreciate individual requirements and provide the most appropriate solution for each specific project.



MANUFACTURING



SEMICONDUCTOR



IT & DATA CENTER



FINANCE



OIL & GAS



TRANSPORTATION



HEALTHCARE



PHARMACEUTICAL



TELECOMMUNICATION



INFRASTRUCTURE



GOVERNMENT



SECURITY

Proven Experience

HITEC expertly provides a full turnkey experience for the customer

By selecting HITEC, our customers are choosing a partner they can trust for the long term. Besides receiving a tailored solution that provides the highest levels of reliability, our after-sales and technical support is a key differentiator and a major factor in selecting HITEC for a project.

To provide global service and support for our customers, HITEC has established a worldwide network of certified partners. By combining the strengths and experience of both HITEC and our global partners, we can both deliver and support high-quality, turnkey power solutions, fit for every location and market requirement.



Customer Support

The HITEC UPS Academy Ensures Availability of Skilled Engineers

Our mission is to serve you by continuously supporting and maintaining your critical-power applications in a safe and cost-efficient way. HITEC is a total "Power Room" solution provider and offers best-in-class support and complete-service solutions that increase the efficiency and reliability of your installation. With our global service network and local presence, we are always close by. Our services are not simply limited to the maintenance of your installation; they go beyond that. Our aim is to uphold your equipment to the highest market standards, safety requirements, and environmental obligations.

At the HITEC UPS Academy we offer a full suite of certified training courses. Our qualified trainers have years of experience, a solid background in the application of our technology, and excellent communication- and knowledge transfer skills. Our educational services are designed to support your technical staff and to keep you in optimal control of your HITEC UPS systems.

Our heritage



1908

HEEMAF

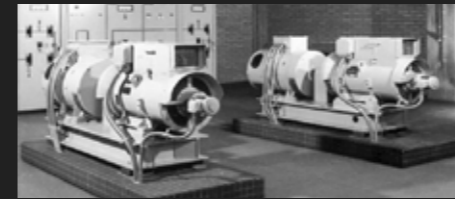

1956

HEEMAF designed and built its first battery-based rotary UPS

1991

First induction coupling with free rotating inner rotor

2015

Launch of the PowerPRO series



1894

Founded by Mr. Hofstede Crull

1943

Specialized in no-break power supply

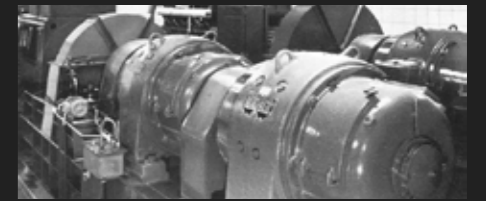

1968

First Dynamic Rotary UPS system

2014

World's most Powerful; Dynamic UPS

2017

HITEC wins the iF product design award

Dynamic UPS Solution

HITEC Power Protection is the world's leading manufacturer of Dynamic UPS systems. To ensure unrivaled reliability, they comprise the highest quality and most rigorously tested components available.

The HITEC Dynamic UPS system performs three essential functions:

1. Cleaning and filtering the utility supply
2. Providing power continuity in the event of a utility failure
3. Generating energy for the entire duration of any utility outage

The unique concept and design of HITEC's Dynamic UPS systems maximizes reliability and provides the customer with the highest available uptime. Depending on the capacity of the available fuel resource, the Dynamic UPS can deliver power for an indefinite period of time. HITEC Dynamic UPS systems operate automatically and seamlessly to safeguard every conceivable and vulnerable load type:

- large motors, pumps, fans
- compressors
- complete fabrication lines
- cooling and air-conditioning equipment
- IT servers, computer systems, and electronic controls

This unique capability ensures that entire production and data-management processes can be continuously protected to deliver maximum uptime.

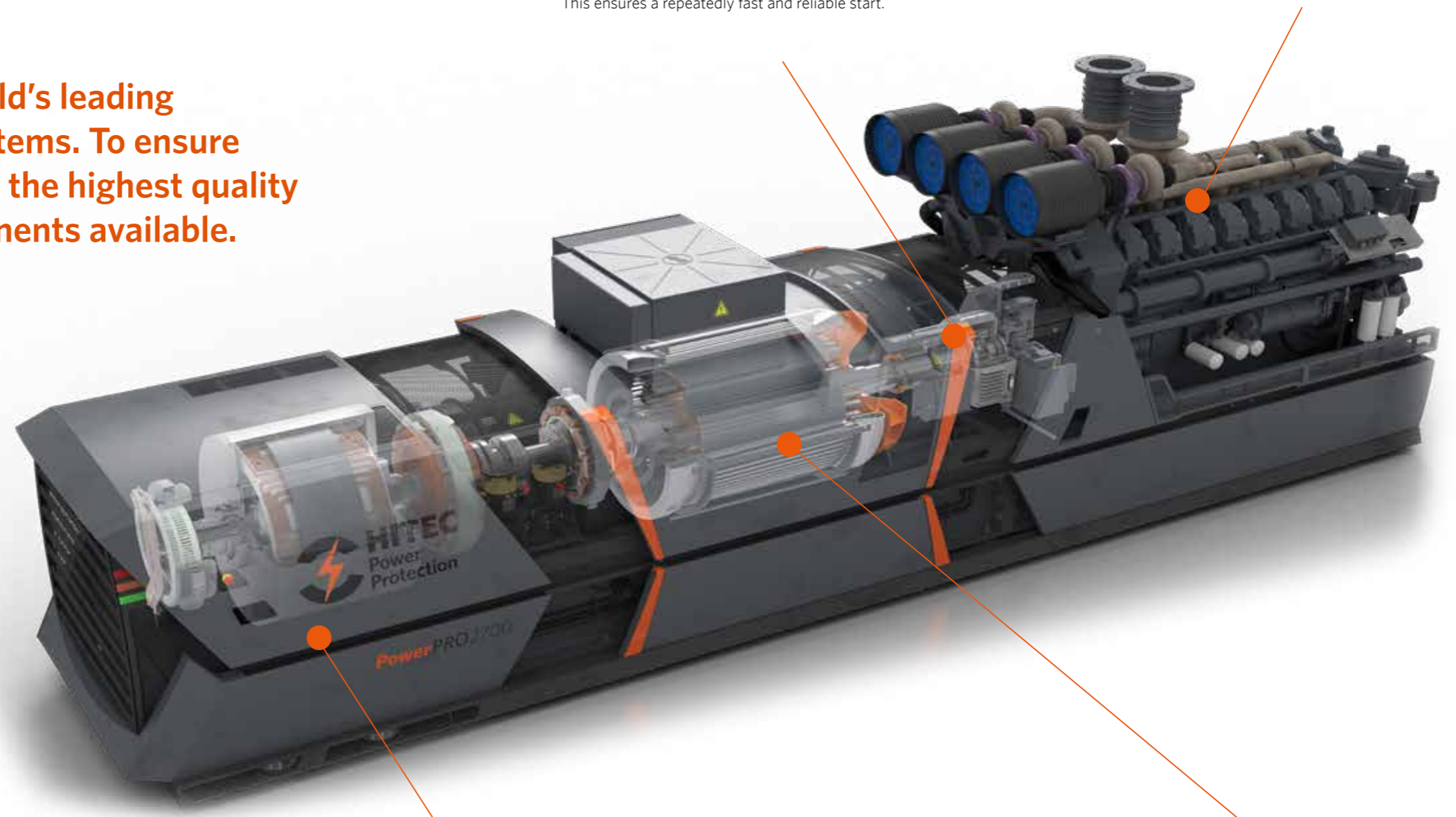

The **FREE-WHEEL CLUTCH** is the mechanical interface between the generator and the engine. The clutch allows the shaft of the generator to rotate while the engine is idle. When the engine starts and the speed of the engine reaches the speed of the generator, the clutch engages automatically, and the engine starts to drive the generator. As a result, the engine starts and ramps up completely without load. This ensures a repeatedly fast and reliable start.

The optimized **ENGINE** sits idle in utility mode and is pre-heated and pre-lubricated to ensure a fast and reliable start. Should the utility power fail or fall outside acceptable tolerance limits, the engine receives a start command and quickly ramps up to full speed and full power. During the time it takes for the engine to deliver full power, the KEM will supply all the energy required to support the critical load.

At the heart of every HITEC UPS system is its **KINETIC ENERGY MODULE**, a unique component that removes the need for any UPS batteries. The KEM stores sufficient kinetic energy to support the connected load during the time taken to start the engine and for it to deliver full power, thereby ensuring a seamless and uninterruptable transition. The KEM is a completely sustainable and environmentally sensitive way of guaranteeing 24x7x365 uninterrupted business continuity without having to use toxic batteries.

In utility mode, the **GENERATOR** (or Alternator) acts as a synchronous motor that maintains the speed of the outer rotor of the kinetic energy module (KEM). It supplies reactive power to the load and works together with the reactor as an active filter. In the event of a utility power failure, the generator, first driven by the energy stored within the KEM, and then by the engine, supplies continuous power to the critical load.

PowerPRO series

The PowerPRO2700 is the latest edition to HITEC's renowned range of Dynamic UPS products. The PowerPRO2700 series has the greatest reliability and uptime, and, with its low energy consumption, it is the most efficient power solution available.

The new standard in continuous power that delivers:

- Lowest possible TCO
- Greatest reliability and uptime
- Highest available system efficiency
- Unrivaled monitoring and reporting
- Rapid and straightforward installation
- Intuitive control and operation
- Compact footprint, highest power density

The HITEC PowerPRO series is paving the way to the next level of efficiency and performance. The evolutionary development step, derived from 65 years of proven manufacturing and engineering experience, has brought a Dynamic UPS product range to the market that is specifically tailored to address the industry's many and diverse power requirements. The PowerPRO's innovative battery-free design increases reliability, saves space, and minimizes environmental impact. The range covers 500 kVA/400 kW to 3600 kVA/2880 kW in a single unit for 50 Hz and 60 Hz frequencies. Multiple units can be combined to build turnkey power solutions of up to 100 MW.

The PowerPRO Range

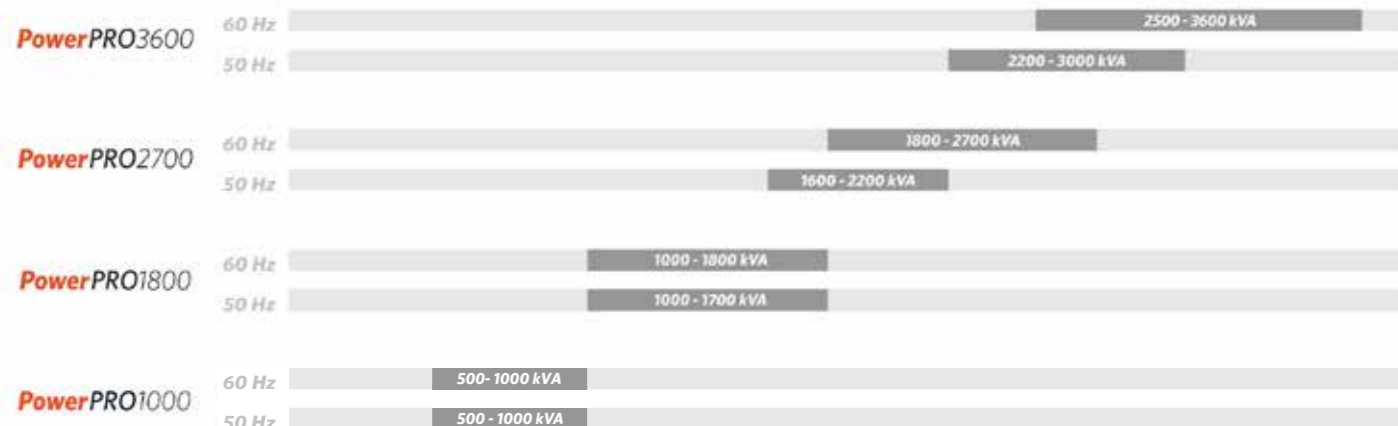

PowerPRO3600

Exceptionally high no-break UPS ratings from 2200 up to 3600 kVA

The HITEC PowerPRO3600 series is designed to reduce the installed footprint by creating the highest power density per square meter/foot in the industry today. The HITEC PowerPRO3600 series is available with UPS ratings up to 2400 kW/3000 kVA at 50 Hz operation, and up to 2880 kW/3600 kVA at 60 Hz. The advantages of the higher ratings are many. Engineers can design the entire facility with UPS power, including large mechanical and motor loads.



PowerPRO1800

Excellent performance and outstanding reliability from 1000 up to 1800 kVA

A diverse range of UPS solutions catering to all your continuous-power needs, the PowerPRO1800 product range, based on proven technology with a solid track record, provides quality solutions that guarantee reliability and durability. This range is tough enough to tackle the world's harshest and most demanding environments. The PowerPRO1800 series is available with UPS ratings up to 1360 kW/1700 kVA at 50 Hz operation, and up to 1440 kW/1800 kVA at 60 Hz.



PowerPRO2700

The new standard for continuous power from 1600 up to 2700 kVA

The PowerPRO2700 series is the latest of HITEC's Dynamic Rotary UPS products. The PowerPRO2700 series has the greatest reliability and uptime, and, with its low energy consumption, it is the most efficient power solution available. In addition, with its small footprint it is also the most compact power solution in today's market. The PowerPRO2700 series delivers the lowest possible TCO and ensures the highest quality of uninterruptible continuous power for mission-critical applications. The unrivaled aesthetics have been awarded the prestigious iF DESIGN AWARD, approving the quality for exceptional design of the PowerPRO2700. The PowerPRO2700 series is available with UPS ratings up to 1760 kW/2200 kVA at 50 Hz operation, and up to 2160 kW/2700 kVA at 60 Hz.



PowerPRO1000

A proven and robust UPS range from 500 kVA up to 1000 kVA

This tried and tested UPS product range provides a compact and robust solution that secures the critical power of your facility. This product is easy to maintain and therefore highly suitable to package as a mobile solution. Each PowerPRO1000 product is built to the highest specification to deliver outstanding reliability, high performance, and increased uptime.

Four Basic Principles

HITEC's unique concept for ensuring uninterruptible, continuous, and clean power rests on four basic principles. Each of these principles contributes to the unprecedented advantages of our Dynamic UPS systems compared to battery-based static UPS systems.

1 INTEGRATED SYSTEM DESIGN

2 LINE-INTERACTIVE SYSTEM

3 ACTIVE POWER FILTRATION

4 BATTERY FREE SOLUTION

FOUR BASIC PRINCIPLES

1 Integrated system design

Efficient, Safe, Reliable,
Compact

A Dynamic UPS replaces a Static UPS plus Standby Diesel Generator. A traditional battery UPS system is composed of a rectifier, batteries, and an inverter. The UPS provides temporary power via its batteries and then transfers the critical load to a standby generator that supplements power for longer outages.

This type of system requires large areas of space, which makes it very costly. Additionally, the energy losses generated in the battery UPS need extensive room ventilation and the batteries must be located in a conditioned room at a constant temperature. These dedicated cooling systems contribute heavily to the life cycle costs.

Our UPS system integrates this traditional system into one. The advantages are clear. Fewer components mean lower installation costs and inherently higher reliability. A HITEC Dynamic UPS has a considerably smaller footprint than a battery UPS system with standby generator. This offers tremendous space and weight savings.

When utility power is lost, the UPS retrieves stored kinetic energy from its induction coupling to support the critical load until the diesel engine takes over. This eliminates the need for environmentally unfriendly and unreliable battery systems.

HITEC's UPS concept is simple and efficient when compared to the battery UPS + standby generator concept: harmonic filters, rectifiers, battery banks, inverters, static switches, standby generator, etc. The HITEC UPS integrates all these functions into one single system.

- Fewer components thus an inherently more reliable design
- Higher MTBF and availability figures
- Lower installation and commissioning costs
- Smaller overall dimensions and floor space requirements
- Rationalized switchboard
- Simplicity: easier to operate and maintain

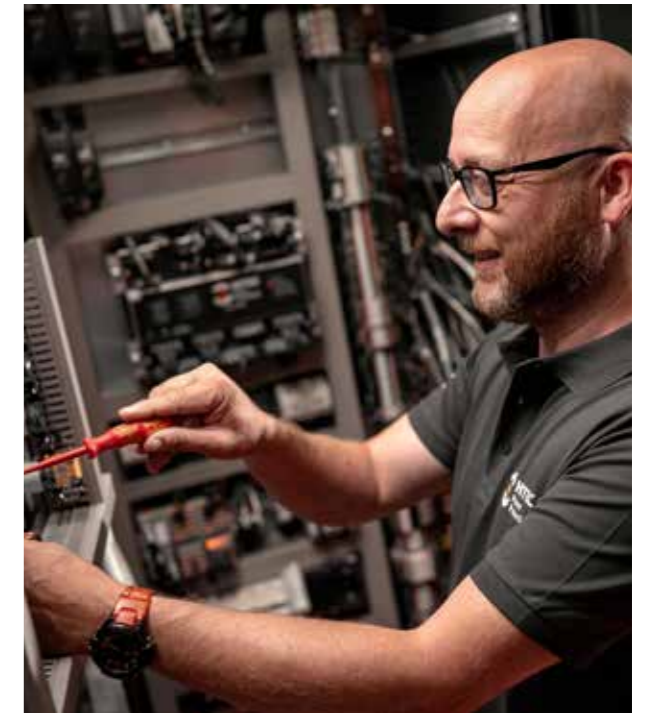

Dynamic UPS

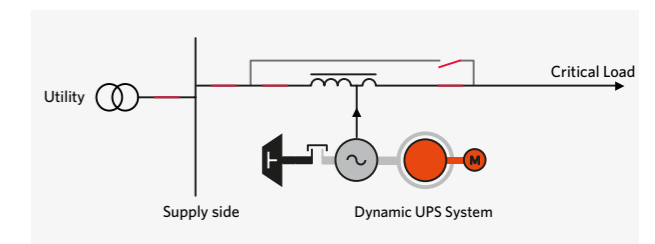

Static UPS

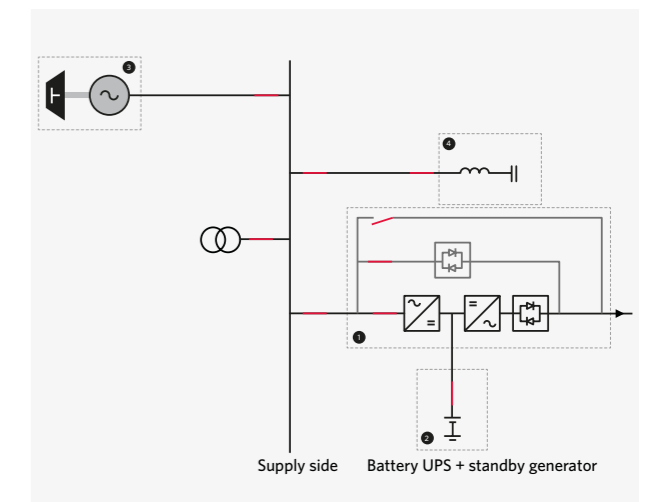

The simplicity of our UPS vs. a battery UPS configuration

1 Double conversion power converter (Static UPS)

2 Batteries

3 Standby generator

4 Harmonic filter

2 Line-interactive system

Line-interactive: Life guarding your mission critical applications

HITEC UPS systems are line-interactive and run in parallel with the utility power. A line-interactive approach does not require any energy conversion, and this provides the basis for a highly efficient, cost effective, and reliable system when compared with a double conversion approach.

A UPS is like a lifeguard that is always alert and ready to jump in and save the load when utility power fails or falls outside specified tolerances. There is no conversion of electrical energy flowing from utility to the critical load, and this makes a HITEC UPS the most efficient and reliable system available.

A traditional battery UPS continuously converts electrical energy through rectifiers and inverters, which creates a common point of failure and reduces efficiency. When factoring in the energy needed to operate a battery and the UPS's air-conditioning requirement, a true realization of the high energy usage associated with the battery UPS system can be derived.



The unique line-interactive concept of a HITEC UPS offers significant benefits. The UPS does not perform the double energy conversion that a battery UPS must execute as soon as the utility power degrades or falls outside specified limits. No power electronics are utilized within the HITEC system; instead, the incorporated synchronous generator is used to supply the load.

- High end-to-end efficiency
- No power conversion; higher MTBF and availability figures
- No generation of harmonic currents/voltages
- Long technical lifetime compared to systems with power electronics (25 compared with 15 years)

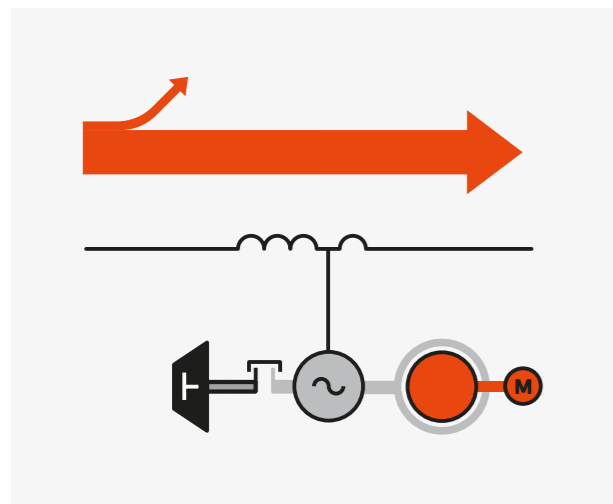

The highly efficient line-interactive system...

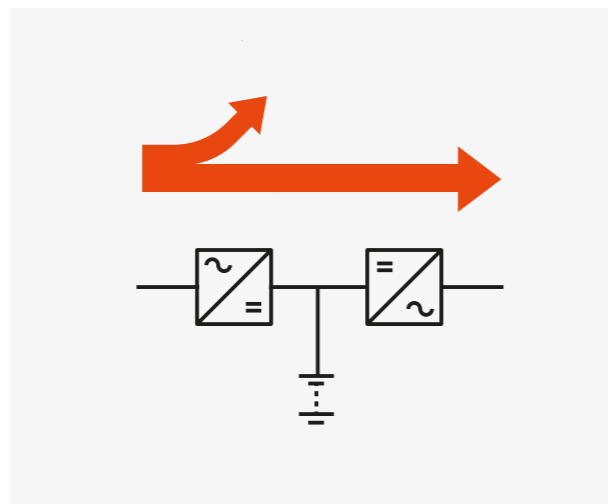

...compared to the traditional double conversion concept

3 Active Power Filtration

Exceptional power quality without power electronics

The combination of the reactor (choke) and synchronous generator acts as a filter to clean the incoming utility supply. This is achieved by setting the position of the tap of the reactor so that the equivalent circuit impedances of the generator and the reactor give a zero impedance path ($X''d + X_c = 0$). HITEC's UPS system does not utilize any power electronics to generate, condition, or convert the output voltage, so it does not produce any harmonics itself, unlike a battery UPS. Instead, it acts as a harmonic filter to both supply and remove load-borne harmonics. Additionally, the generator supplies the reactive power drawn by the load. The result is that, regardless of load profile, the utility is presented with a power factor that is always close to unity.

Outstanding qualities of the active filter:

- High short-circuit output capacity. The system does not need to go to by-pass (use the utility) to clear an output fault
- Reactive output power is supplied by the generator (input pf >0.98)
- Dips and spikes in the utility voltage are blocked
- Compensation of prolonged deviations of the utility voltage
- Filtering of utility-borne harmonic voltages
- Filtering of load-side-borne harmonic currents

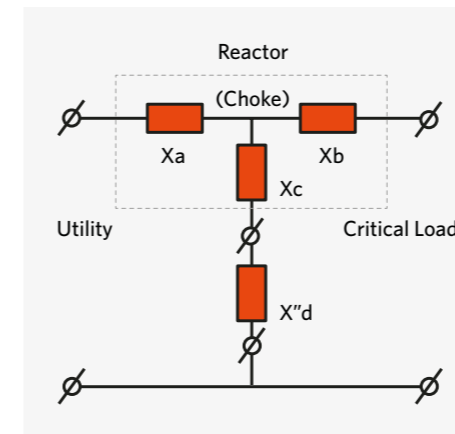

Electrical equivalent diagram of the active filter

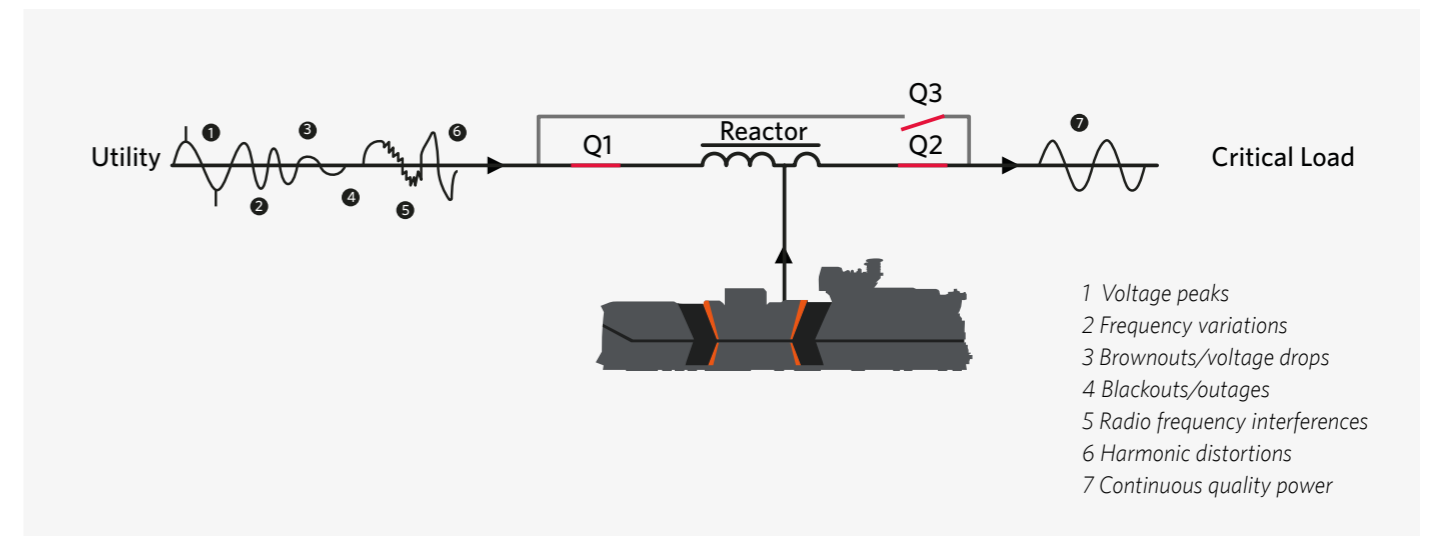

- 1 Voltage peaks
- 2 Frequency variations
- 3 Brownouts/voltage drops
- 4 Blackouts/outages
- 5 Radio frequency interferences
- 6 Harmonic distortions
- 7 Continuous quality power

A Dynamic UPS solution acts as a filter for all sorts of utility disturbances.

4 Battery-free solution

HITEC's Dynamics UPS solution uses stored kinetic energy to bridge the engine start time upon a utility power failure. It is a battery-free concept that was invented and patented by HITEC. The heart of a battery UPS is also its weakest link. The huge number of batteries required constitutes a sizeable problem that, to the user's frustration, only becomes apparent after several years of operation.

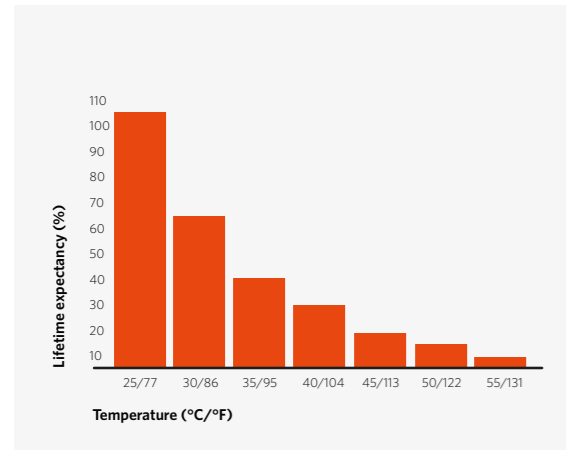

A battery's lifetime expectancy drops fast at higher ambient temperatures.



The difference between theoretical and actual battery lifetime.

Battery related issues you won't face with a dynamic UPS

Lifetime expectancy

Theoretically, battery lifetime is 5 to 15 years; practically, they last for only 3 to 5 years. The economic lifetime of a battery UPS is 10 to 15 years, whereas a HITEC UPS will last for 25 years or more.

Temperature sensitivity

Battery capacity decreases significantly at low temperatures, while lifetime halves every 10°C (18°F) above 20°C (68°F). Installation in conditioned rooms is a must.

Environmental effects

Batteries contain environmentally harmful materials; used batteries are chemical waste. Disposal costs are high – particularly for lithium-ion batteries.

Maintenance

The only sound method to monitor battery capacity is discharge testing, which is time consuming because the battery must be disconnected from the UPS.

Features & benefits

No batteries are used in a HITEC UPS system; instead, kinetic energy is used to bridge diesel start time. The system is not sensitive to the variety of problems associated with the use of batteries.

- No re-investments every 5-7 years for new batteries
- No need for a dedicated climate-controlled battery room
- Reduced floor space requirements
- No battery disposal costs every 5-7 years (so no chemical waste!)

Sustainable and Environmentally Responsible

We innovate for a better tomorrow

Every product we build and service we provide takes into account how it affects our world now and in the future. We are growing our portfolio while protecting the globe with safety, quality and integrity at the foundation of every decision we make.



CARBON FOOTPRINT

Eliminating unnecessary diesel engine starts reduces emissions



SUSTAINABILITY

Rotary lasts longer and you won't have to send batteries to a landfill



PUE

Transformerless medium voltage systems bring PUE to new lows



EMISSIONS

Our equipment is TA-Luft or EPA tier rated – the strictest standard in the industry



ENERGY COST

We consume less energy by right-sizing equipment to the load



ENERGY LOSSES

Through our efficiency advantage, we save thousands of kilowatt hours

Unit Operation

Innovation by intelligent system design

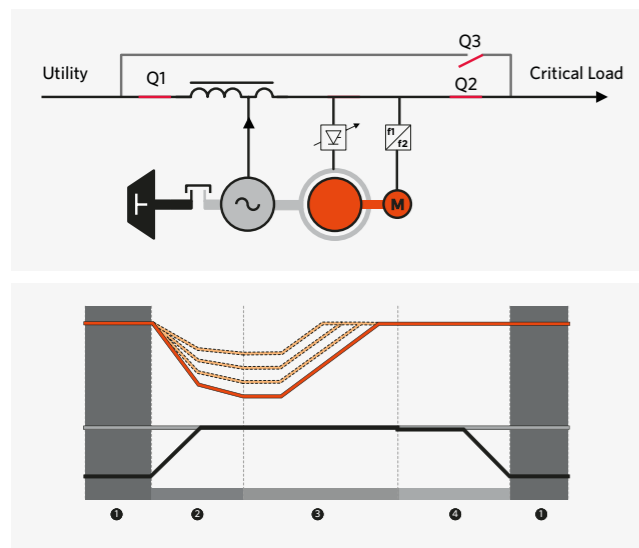
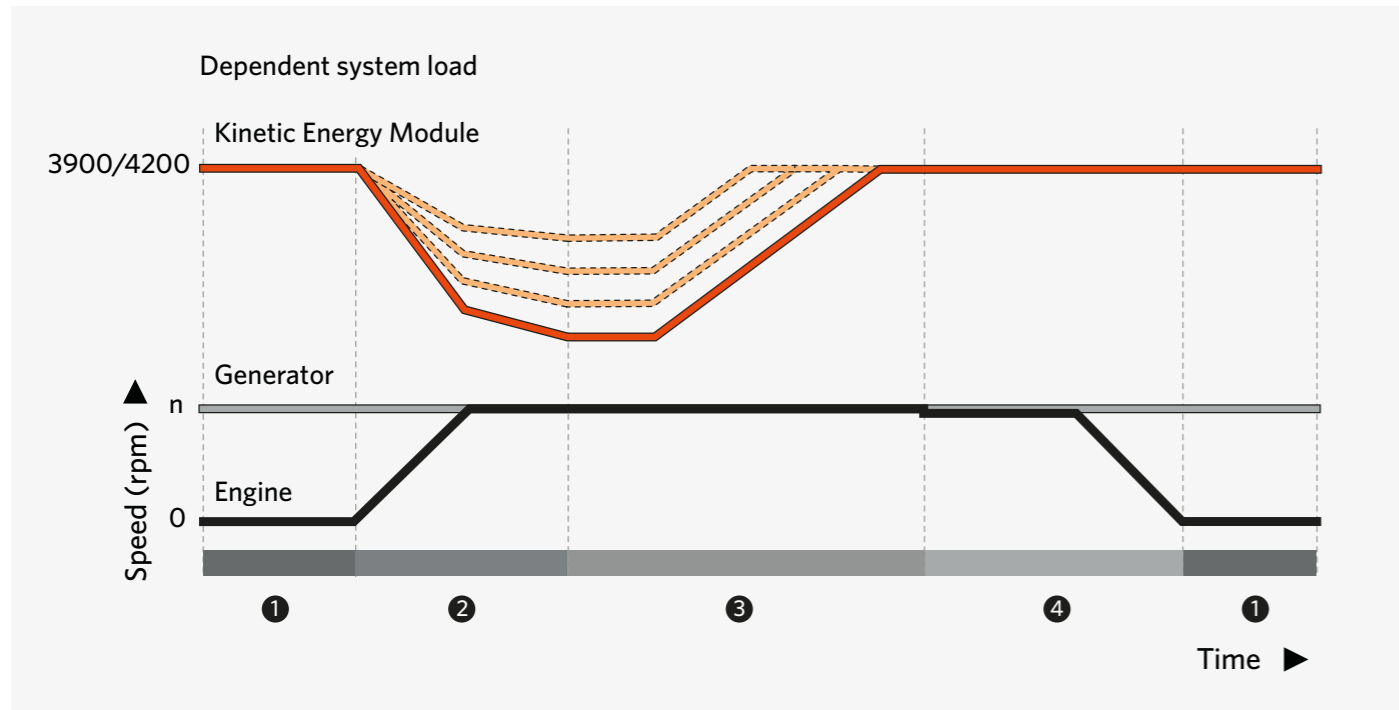

1 Utility mode

In utility mode, the reactor and the generator function as an active filter that prevents any disturbance from the utility reaching the critical load. The generator runs as a motor and drives the outer rotor of the kinetic energy module at a speed of 1500/1800 rpm. The pony motor AC machine (M) speeds up the inner rotor to a speed of 3900/4200 rpm and creates an absolute delta speed of 2400 rpm and thus stores kinetic energy.

2 Change-over to engine mode

In the event of a power interruption or an unacceptable deviation in the supply of utility power, the circuit breaker Q1 opens. The Kinetic Energy Module's DC windings are then excited, thus allowing a transfer of stored kinetic energy from the outer rotor to the inner rotor. The speed of the generator remains constant at 1500/1800 rpm.

Simultaneously, the engine starts and ramps up to 1500/1800 rpm in less than 2 seconds, after which the free-wheel clutch engages automatically. For the next few seconds, the engine together with the kinetic energy module drive the generator to ensure a proper supply of power to the critical load. Within 5 to 10 seconds, the engine is the sole provider of power to the load.

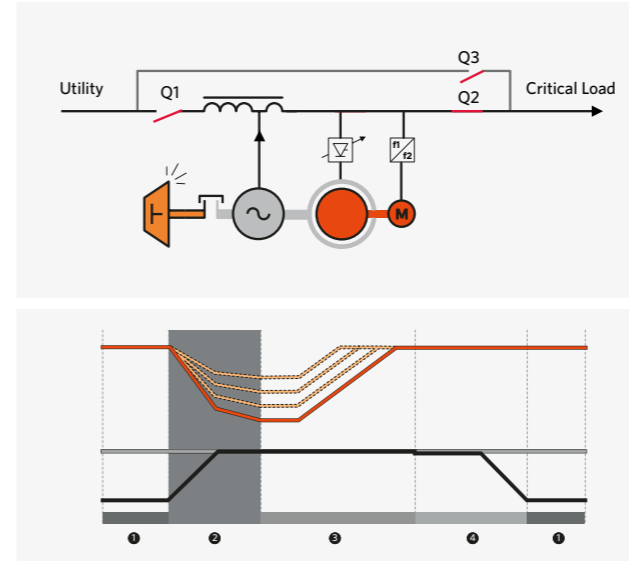

3 Engine mode

When in engine mode, the inner rotor is re-energized, causing the inner rotor to ramp up to 3900/4200 rpm again. The speed of the engine is monitored and digitally controlled to ensure a constant output frequency.

While in engine mode, the output frequency remains within narrow tolerances, even if the system encounters high load steps, since the kinetic energy module will be utilized to support the diesel engine.

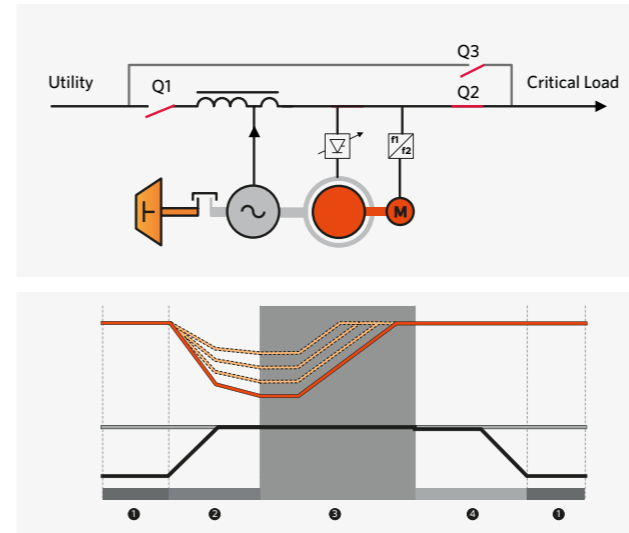

4 Back to utility mode

After utility power has stabilized, the UPS synchronizes with utility power and closes Q1. The engine then ramps down to 1450/1750 rpm, and as a result the free-wheel clutch disengages. Simultaneously, the generator returns to its motor operation and maintains the speed of the outer rotor of the kinetic energy module at 1500/1800 rpm.

The engine will continue to run for a short time in a no-load condition to cool down. After the engine has completed its cool-down run, it will shut down and return to standby mode.

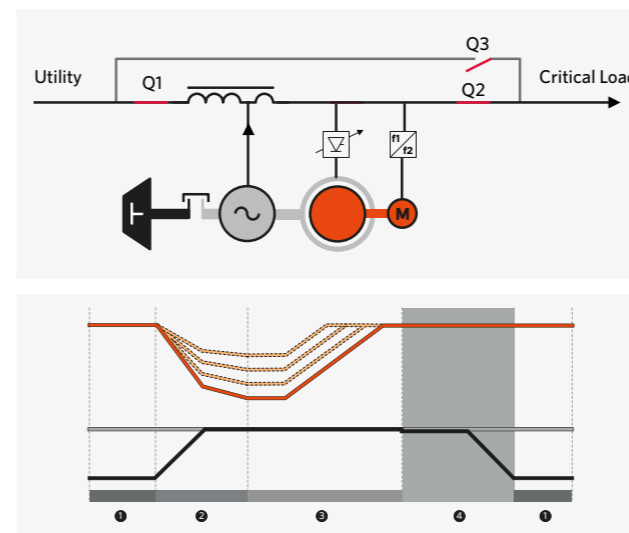

System Configurations

Features

Dynamic UPS systems can be delivered in a variety of configurations. From a single module to a large multi-module configuration, each configuration can be tailored to meet your specific needs.

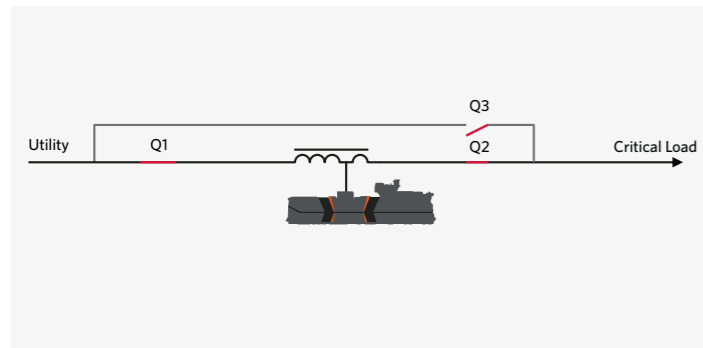

SINGLE SYSTEMS

In a single output configuration all components (generator, kinetic energy module, engine, and reactor) are rated to provide continuous and clean power to the critical load.

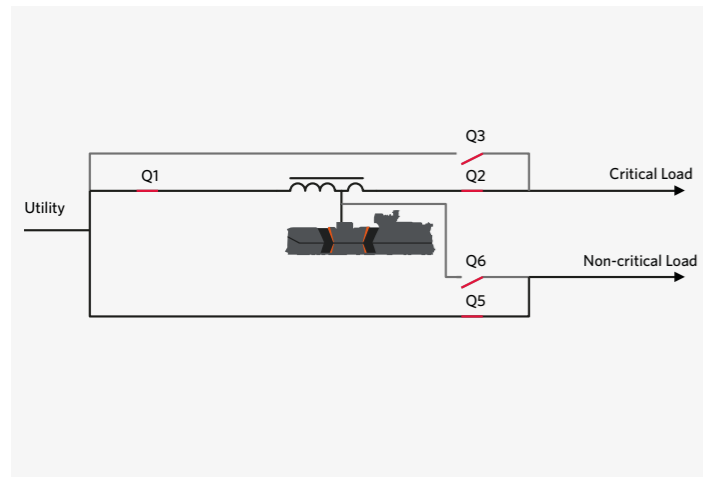

DUAL OUTPUT UPS SYSTEM

To ensure sufficient short circuit capacity and guaranteeing narrow voltage tolerances, the UPS's generator is overrated. This excess power can be used to supply non-critical loads. The engine's rating must then be increased to supply both the critical and non-critical loads. This configuration is known as the dual output system. When the utility fails, the UPS will protect the critical load. As soon as the engine has started and has stabilized the critical load, the UPS then assumes the non-critical load by closing circuit breaker Q6. Virtually no additional cost or space is required.

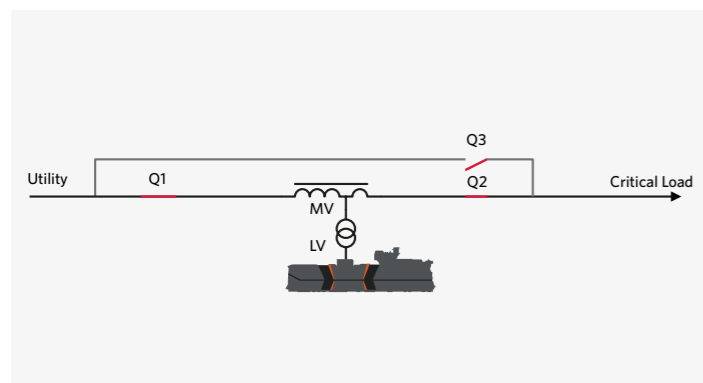

MEDIUM VOLTAGE SYSTEM

For higher power ratings, medium voltage (MV) systems up to 22,8 kV can be offered. HITEC Power Protection offers two types of medium voltage configurations. The first option incorporates a low voltage power module with an additional step-up transformer; the other incorporates a medium voltage power module. Circuit breakers and the reactor will always be configured at the medium voltage level. Single output, dual output, and medium voltage systems are available in a variety of configurations.

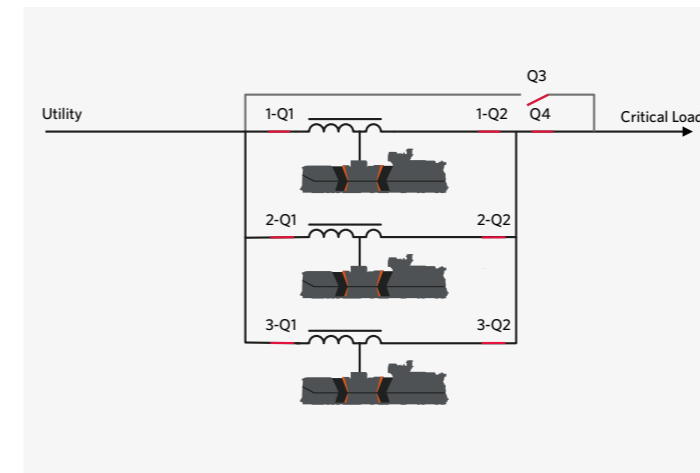

PARALLEL / PARALLEL REDUNDANT SYSTEM CONFIGURATIONS

For load requirements over our largest single module unit (3600 kVA), parallel configurations can be designed for increased output. Paralleling units is also considered when redundancy is required. The most common redundant configuration is "N+1".

When two units are required to supply the critical load, another unit will be installed to provide backup should a unit fail. The total number of units that can be installed in parallel is limited by the total output current/short circuit current. Currents over 6000 A are not practical, i.e., total output power is limited to approx. 4000/5000 kVA at 380/480 V.

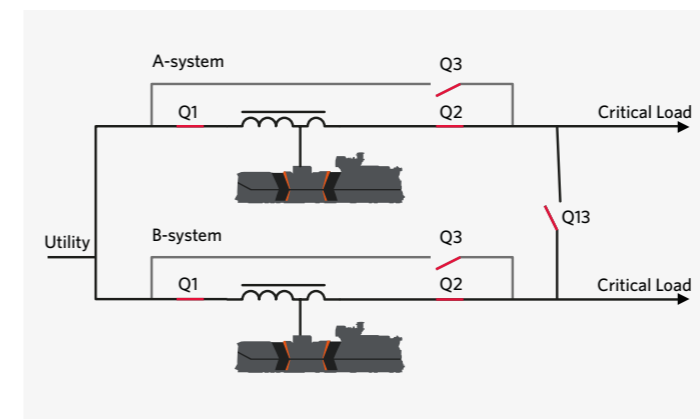

MASTER-SLAVE CONFIGURATION

An alternative configuration for two parallel units is the master-slave configuration. This option is more appropriate if two groups of critical outputs are separated without a common point of coupling. The control system maintains synchronization between both units, ensuring that the tying breaker (Q13) can be closed at any time in the event of failure or maintenance. No common point of failure is present.

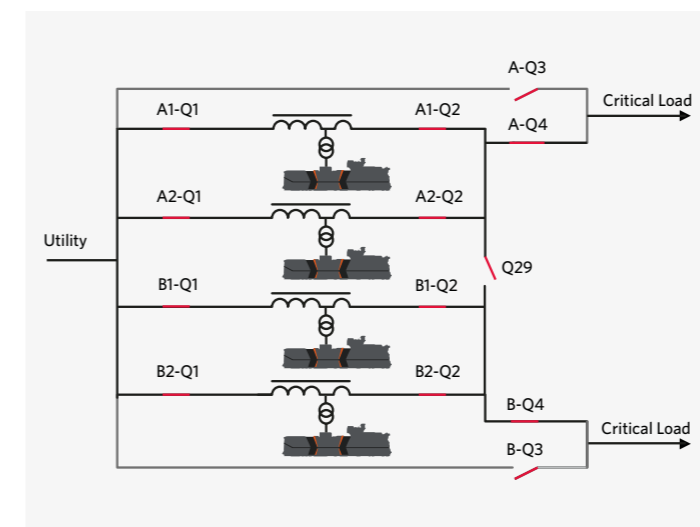

CROSS-LINK SYSTEM CONFIGURATION

In the parallel configuration, the total critical load is connected to one output bus. In situations where there are two separate independent loads, a cross-link (or Q29) configuration can be used. As in a parallel system, the redundancy is N+1 over the total amount of units, but during normal operation the system acts as two independent parallel systems. However, the redundancy is shared between the two systems and, if one of the two parallel systems is overloaded, closing the Q29 breaker will make use of the surplus of power available in both systems. When in Q29 mode, if an output bus failure occurs, it will be limited to the bus causing the fault; the other system will be disconnected by opening Q29. Redundancy is only shared between critical loads; non-critical loads do not have a cross-link connection. Therefore, the cross-link virtually eliminates single points of failure in the bus-structure. The limitations of the system are equal to that of a parallel system.

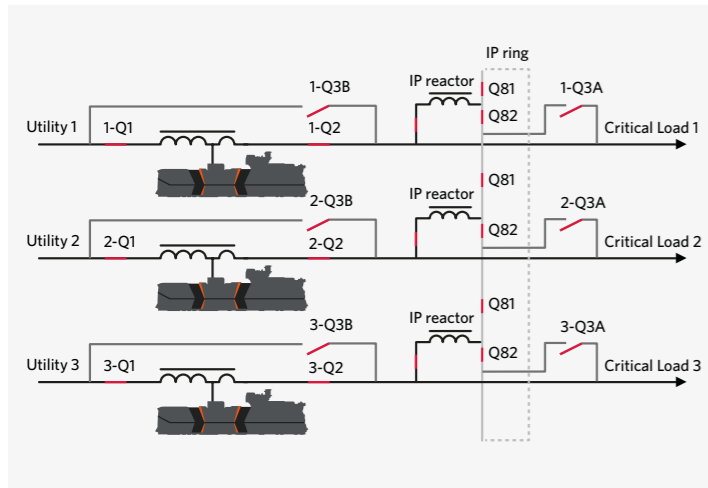

ISOLATED PARALLEL SYSTEM CONFIGURATION

The isolated parallel system configuration combines the fault tolerance of redundant systems with the load-sharing capabilities of a parallel system.

The isolated parallel configuration connects multiple units together, thereby creating redundancy, while at the same time maintaining isolation between units. Active power can then be shared between units, while load faults will be kept isolated from each other. Therefore, a fault on one load will not influence other loads.

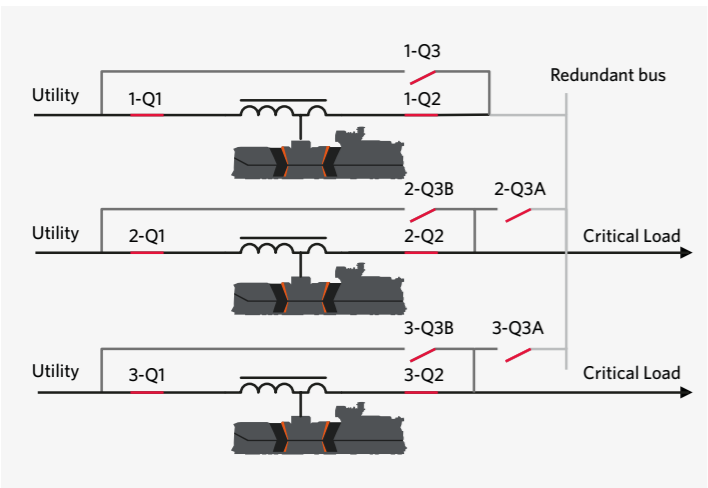

ISOLATED REDUNDANT SYSTEM CONFIGURATION

Traditionally, a parallel redundant configuration would be used if redundancy were required. With an isolated redundant configuration, redundancy is created on the basis of standard single units.

All individual units support their individual critical loads. In an "N+1" configuration, these systems have one redundant unit as a backup. The backup unit normally operates in a no-load condition. If one unit fails or is taken off-line, the critical loads are automatically transferred to the redundant unit (closing Q3A) via closed transition instead of going to bypass. Additionally, the non-critical load can be connected to the redundant unit using the available UPS power. During maintenance or a module failure, the non-critical load will be transferred back to the utility supply and the critical load will be maintained.

All circuit breakers in this configuration need to be rated to each unit's nominal output current. This configuration can be used for much higher power ratings as compared to the parallel redundant configurations.

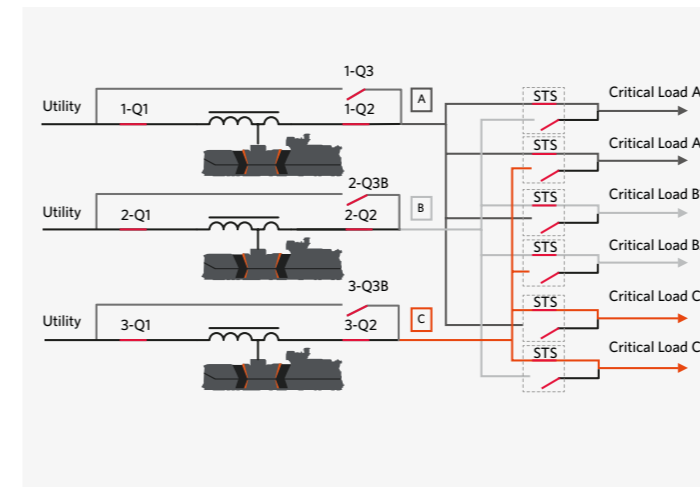

DISTRIBUTED REDUNDANT CONFIGURATION

In the isolated redundant configuration, the redundant unit is normally supplementing a non-critical load or running at no load at all. This can be overcome with the distributed redundant design.

Distributed redundant systems are normally designed for "N+1" redundancy. No single module is assigned as a redundant unit. Instead, this role is shared equally among all modules. In the event of a single unit failure, its load will be shared proportionately across the remaining units. The load transfers are accomplished through Static Transfer Switches (STS). The advantages are the elimination of single point failures and equal load sharing among all units.

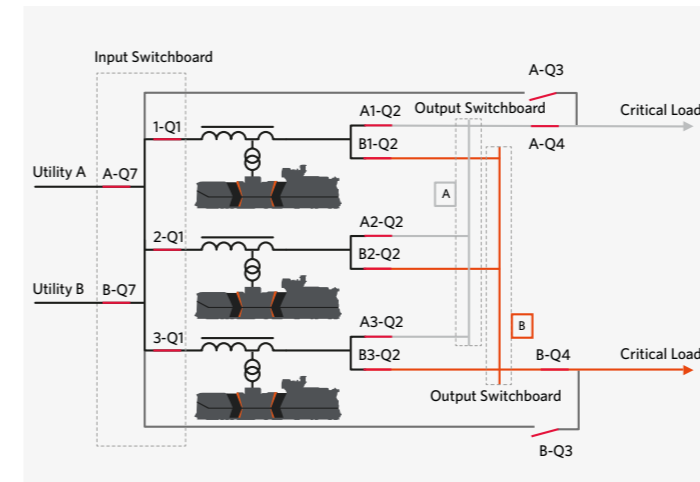

DUAL UPS BUS SYSTEM CONFIGURATION

A Dual UPS Bus system is a "concurrently maintainable" Parallel System configuration at Medium Voltage. This means that all parts in the system can be maintained while still supplying the customer's downstream loads with UPS power. The Dual UPS Bus system has following features:

- An additional UPS unit to those for the maximum customer load; known as N+1 redundancy
- Duplication of the common critical load output to an A and B side
- Housing switchgear in a separate input, critical output A and output B switchboard
- Differential/directional protections at Q2's circuit breakers to be considered (better isolation of UPS buses)
- Maintenance at UPS unit level is allowed due to redundancy
- Maintenance at output switchboard A/B level is allowed due to redundancy
- Allowing maintenance at input switchboard level is possible when the UPS units are in engine mode
- Independent operation of both critical loads A/B, and therefore fault tolerant at failure of main components such as circuit breakers or a control system
- Possible 30-degree phase angle between both critical loads (A/B)
- Optional "Critical Load Linked Mode" to allow downstream make-before-break transitions between both critical loads A/B at maintenance

System Configurations

Advantages

System configurations	Advantages
Single Systems	In a single output configuration all components (generator, kinetic energy module, engine, and reactor) are rated to provide continuous and clean power to the critical load.
Parallel Redundant (PR)	Simplest and most compact means of achieving redundancy between UPS units and of supporting very large or multiple loads.
Master Slave (MS)	Eliminates a common UPS output bus-bar.
Cross Link (CL)	Virtually eliminates the common output bus-bar. On multi-UPS unit systems, far fewer UPS units needed to achieve required redundancy than in an MS system.
Isolated Parallel (IP)	No common output bus-bar due to additional tie breakers and isolating reactors. Efficient and flexible use of the system redundant capacity.
Isolated Redundant (IR)	No common output bus-bar due to separation of loads and UPS unit outputs. Fewer breakers and reactors required than in an IP system.
Distributed Redundant (DR)	No common output bus-bar due to separation of loads and UPS unit outputs. Fewer breakers and reactors required than in an IP system. Efficient and flexible use of the system redundant capacity.
Dual UPS Bus (DU)	A dual UPS bus system is a "concurrently maintainable" parallel system at medium voltage. This means that all parts in the system can be maintained while still supplying the customer's downstream loads with UPS power.



Tailored Solutions for Every Location

Whether the UPS system is in a building, fully containerized externally, or inside a weatherproof canopy on a concrete slab, we can meet specific local environmental, climactic, and client requirements with engineered noise reduction, exhaust and acoustic treatments, air filtration, and sand trap solutions.

Customized installation and containment

Our Dynamic UPS systems can be installed in numerous ways depending on the site conditions and the noise emission requirements. They can be integrated within new or existing buildings or located externally within a container or weatherproof canopy. Each of these approaches can be combined with corresponding noise reduction, fire protection, and other safety and environmental protection measures.

Our global project teams are highly experienced in delivering packaged solutions for defense applications and in meeting the exacting standards demanded by the world's military.



Compliance is the Key to Safety

Our Dynamic UPS systems are compliant with the latest mandatory product certifications and with the world's most stringent emission control measures.

Wherever you are, whatever your application, we work with you, our customers and business partners, to achieve compliance and to enhance the safety and quality of our solutions.

HITEC Power Protection works continuously on setting new standards for sustainability and the creation of a safe working environment.

Customized Aftertreatment Installations

HITEC has unrivaled experience in the design, implementation, and servicing of exhaust aftertreatment solutions. We install catalysts (SCR) to reduce the nitrogen oxide (NOx) present in the exhaust gas of engines so that they comply with the most stringent emission standards. We also implement flue designs for a wide variety of structures and can incorporate the correct catalysts, soot filters, and monitoring systems to both ensure compliance and meet client-specific performance criteria against various fuel specifications.



Earthquake Protection

To avoid serious damage in the event of an earthquake, buildings, technical infrastructures, and support equipment such as UPS systems must be designed as earthquake-proof. Therefore, UPS manufacturers need to address the demands of earthquake safety and deliver equipment solutions that can withstand seismic events. HITEC supports critical installations at numerous locations throughout the world where earthquake-proof design is essential. Our global project and engineering teams deliver a proven range of seismic-resilient solutions, including shock and vibration restraints, specialized dampers, and isolated pads that separate the UPS system from the structure. Panels and auxiliary equipment can also be insulated from the effects of an earthquake using absorption and isolation packages that dampen the earthquake shockwaves

Upgrades

Our installations are designed to operate for many decades and are upgraded throughout their life to incorporate the latest technology. Because of our equipment's flexibility, our in-house experts can offer you a range of upgrade solutions to ensure that your installation is kept at the highest market standards and meets all safety and environmental requirements. Our qualified upgrade programs are designed to extend the lifetime of your installation, reduce cost, increase efficiency, and enhance the control, monitoring, and functionality.

Commitment

Our relationship with our customers does not end with the installation of a dynamic UPS system. We believe that even the best technology is only as good as the service that supports it. Therefore, we have established a global service network that cares and maintains for all our installations world-wide. Our company's commitment to technical excellence, innovation, and customer service has resulted in us maintaining a leading position in the market and being a trusted global business partner.

"Possibilities for retrofitting of installations"

Rental Solutions

To meet your needs at a moment's notice, HITEC offers a fleet of dynamic UPS units. Our portable dynamic UPS solutions are available for temporary or specific power backup requirements. We support applications that have mission-critical power needs, such as hospital renovations and sporting events. Long-term rentals and even "try-before-you-buy" solutions are also provided. Units can be dispatched to suit a variety of operational configurations and voltages. Our rental fleet has a total capacity in excess of 10 MW, and with units of various capacities we can accurately match individual customer needs. Our mobile fleet is dedicated to ensuring that your facility is protected regardless of location.





Total Solution Provider

We promote long-term service partnerships that deliver quality, reliability, and value throughout the lifecycle of your equipment. Our customized service solutions encompass an advanced remote monitoring platform, performance reporting, service inspections, maintenance, training, and service consultation. Our helpdesk is dedicated to providing timely, high-quality support to all of our customers worldwide, 24x7x365. We provide the partnership that fits your needs and ensures that "Power is in your Control".

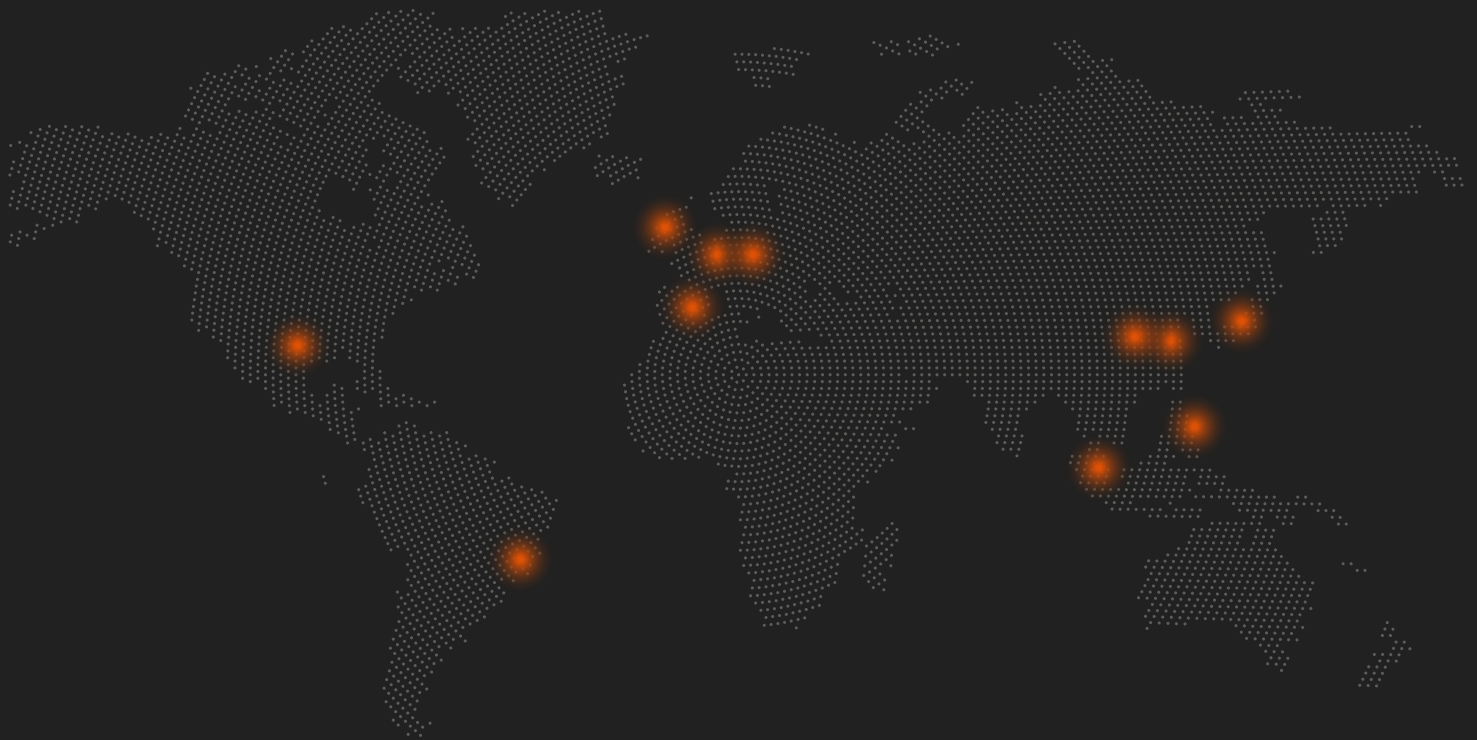

HITEC Power Protection BV
Bedrijvenpark Twente 40
7602 KB Almelo
The Netherlands
Phone +31 546 589 589



[hitec-ups.com](https://www.hitec-ups.com)

**CONTINUOUS POWER
IN YOUR CONTROL**