

CONTINUOUS POWER IN YOUR CONTROL



PowerPRO3600



 AIR WATER GROUP

A reliable and resilient support infrastructure mitigates operational risk and thereby optimizes the availability of power to the business. Functional design requirements must meet key business objectives and the management philosophy of the site. The need for scalability of capital

investment, modularity in approach and increasing power density influence the choice of UPS systems for providing conditioned, uninterruptible and continuous power supply to critical loads. The UPS from HITEC PowerPRO3600 series meets all of these requirements.

CONTINUOUS PRODUCTION

Exceptionally High No-Break UPS Ratings

The HITEC PowerPRO3600 product line is designed to reduce installed footprint by creating the highest power density per square foot in the industry today. The HITEC PowerPRO3600 series is available with UPS ratings up to 2400 kW/3000 kVA at 50 Hz operation, and up to 2880 kW/3600 kVA at 60 Hz. The advantages of the higher ratings are many. Engineers can design the entire

facility with UPS power, including mechanical and motor loads. The HITEC PowerPRO3600 supports 100% of the facility with uninterruptible power, using fewer machines to support a given load. Fewer machines mean lower installation and maintenance cost, resulting in lower CAPEX and OPEX.

Predictable Lowest Total Cost of Ownership

The HITEC PowerPRO3600 has a unique combination of features that give our customers outstanding performance plus a significantly lower Total Cost of Ownership. It is optimized to meet energy efficiency demands with an end-to-end efficiency of up to 97%.

The PowerPRO can also operate in an unconditioned space, saving not only the cost of expensive cooling systems, but the subsequent maintenance, repair, and energy costs as well. For these reasons HITEC is the standard of value in the UPS industry.

Optimized for Highest Efficiency

The HITEC PowerPRO3600 has many innovations that provide end-to-end efficiency of up to 97%. The generator and reactor have been optimized to work together for lower losses. Controlled Energy Storage Optimization (ESO) mode automatically monitors the

connected load and reduces the flywheel speed in response to an extended period of partial loads. This reduces stranded capacity during partial loads, but restores the flywheel to full speed as loads increase.



Feature

Benefit

High energy efficiency (up to 97%)

- Lower operational cost
- Lower Power Usage Effectiveness (PUE)
- Less waste heat

Low space requirements (40-60% less than static UPS)

- High power density
- Reduce building costs
- Reduced HVAC costs

Integrated functionality combining UPS and standby diesel generator

- Robust, compact and modular design
- High system availability
- Active filter supplies conditioned power

No use of batteries

- No battery replacement every 3-5 years
- No chemical waste
- Compact and simple
- Environmentally friendly

Versatile Hardware Configuration

The HITEC PowerPRO3600 concept is based on proven Dynamic UPS technology. The design combines different functionalities using pre-engineered modules and components that are arranged to enhance their efficiency. The diesel engine and generator can function as a traditional genset even with the energy storage

system disconnected. Another benefit is that the generator, ETM and flywheel can work in unison as a rotary UPS even when the diesel is disabled for maintenance. These elements can also provide kVAR and harmonics mitigation, plus ride-through energy to support the total system.

The flywheel is available in different sizes to match the required output power and ride-through time. With variable speed controls, the amount of energy stored can be controlled, to match the power need, hence increasing the overall system energy efficiency significantly, especially at partial loads.

The Energy Transfer Module (ETM) is the heart of the system. It transfers the kinetic energy stored in the flywheel to the generator, so guaranteeing an uninterrupted supply of power.

The freewheel clutch is a robust mechanical machine, self lubricating and with low maintenance requirements. It operates without any external control thereby ensuring a "shock-free" delivery of power.

The diesel engine is kept in optimal condition to enable a short start and quick load acceptance. Emission optimized engines are available to comply with carbon emission standards from EPA or TA. Diesel Start Delay function is available to prevent unnecessary diesel starts.

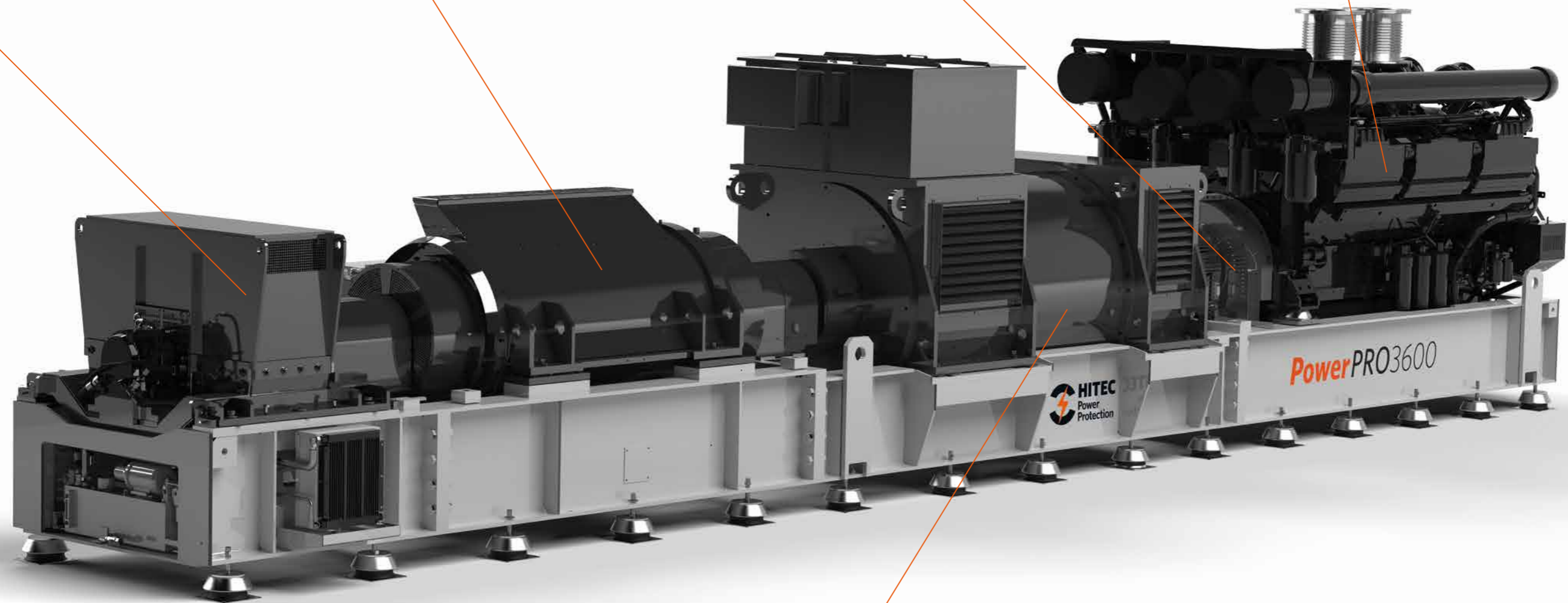

The generator is matched with the nominal load and reactor ensuring good dynamic system response. Careful design of the exact characteristics of the generator and reactor provides an active filter to remove both utility and load-borne anomalies like voltage spikes, frequency variations and harmonic distortions. Load and utility short circuits can be cleared without the need to switch the load to bypass. The generator also enables power factor correction close to unity.

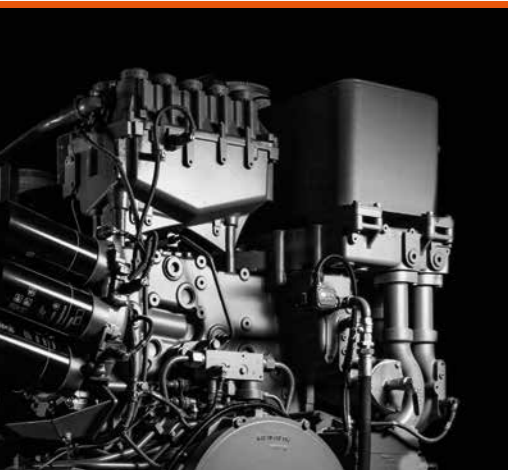

Low-Stress Energy Storage Technology

The HITEC PowerPRO3600 energy storage system has two elements: an Energy Transfer Module (ETM) and a high-energy, low-speed flywheel. The ETM spins with the generator at 1500 rpm/50 Hz and at 1800 rpm/60 Hz. The flywheel spins at approximately 2900 rpm. This lower speed allows extended maintenance intervals.

System Advantages

Reliability

A straightforward design with proven technology, a brushless system and low speed flywheel ensure high reliability.

Efficiency

The most efficient fully operational UPS system in the market, up to 97%.

Power factor correction

The input power factor remains close to unity, minimizing power factor charges from the utility.

Dynamic filter

The choke and generator act as a rotating filter, removing harmonics from both the input and output.

Voltage regulation

The output voltage is controlled independent of the input voltage.

Small footprint

The installed size of the system is 40 to 60% less when compared with static UPS systems.

Energy Storage Optimization mode

Energy Storage Optimization mode (ESO mode) reduces the accumulated flywheel energy to the level that is needed to guarantee UPS function, thus saving energy.

Diesel Start Delay

Diesel Start Delay mode (DSD mode) prevents unwanted diesel starts for short utility interruptions, saving fuel and equipment wear.

Typical System Specifications

System specification:

Allowable Power Factor	between 0,8 lagging and 0,9 leading
Rated Power Factor	0,8
Nominal voltage:	400/480V
Nominal frequency:	50/60 Hz

Input specifications:

Input mains-voltage fluctuations:	± 10 % (up to -50% / +30%)
Input frequency tolerance:	± 0,4 Hz (up to ± 3%)
Input power factor under nominal conditions:	≈ 1
Max. reverse current during up-stream short circuit:	up to 2 * I _n

Output specifications:

Output voltage steady state:	≤ 1 %
Output voltage dynamic (during mains interruption):	≤ 5 %
Output frequency utility operation:	as utility frequency
Output frequency Steady state variation:	≤ 0,5 %
Output frequency Dynamic variation:	≤ 2 %
System voltage symmetry:	≤ 2 %
Radio interference level (EN 55.011):	Class A

Diesel engine:

Operating with diesel fuel corresponding:	HVO, EN590, Grade No.2D per ASTM D975
---	---------------------------------------

Engine power (standby power) corresponding:	DIN/ISO 3046
---	--------------

Ambient conditions:

Ambient temperature:	min. 5 and max. 40 °C
Humidity:	max. 85% non-condensing
Altitude:	max. 400 m

Each system will be designed and configured to perform optimally to your requirements and site-specific circumstances.

Frequency (Hz)	Voltage	System Power (kVA)	Rated Power (KW)	Length (mm)	Width (mm)	Height (mm)	Weight (tons)
50	400	3000	2400	11.935	2.054	2.567	38
50	400	2850	2280	11.403	2.054	2.581	37.8
50	400	2500	2000	11.181	2.054	2.737	35
60	480	3600	2880	11.963	2.058	2.567	38.6
60	480	2850	2280	11.403	2.054	2.581	37.8
60	480	2500	2000	10.780	1.721	2.547	28

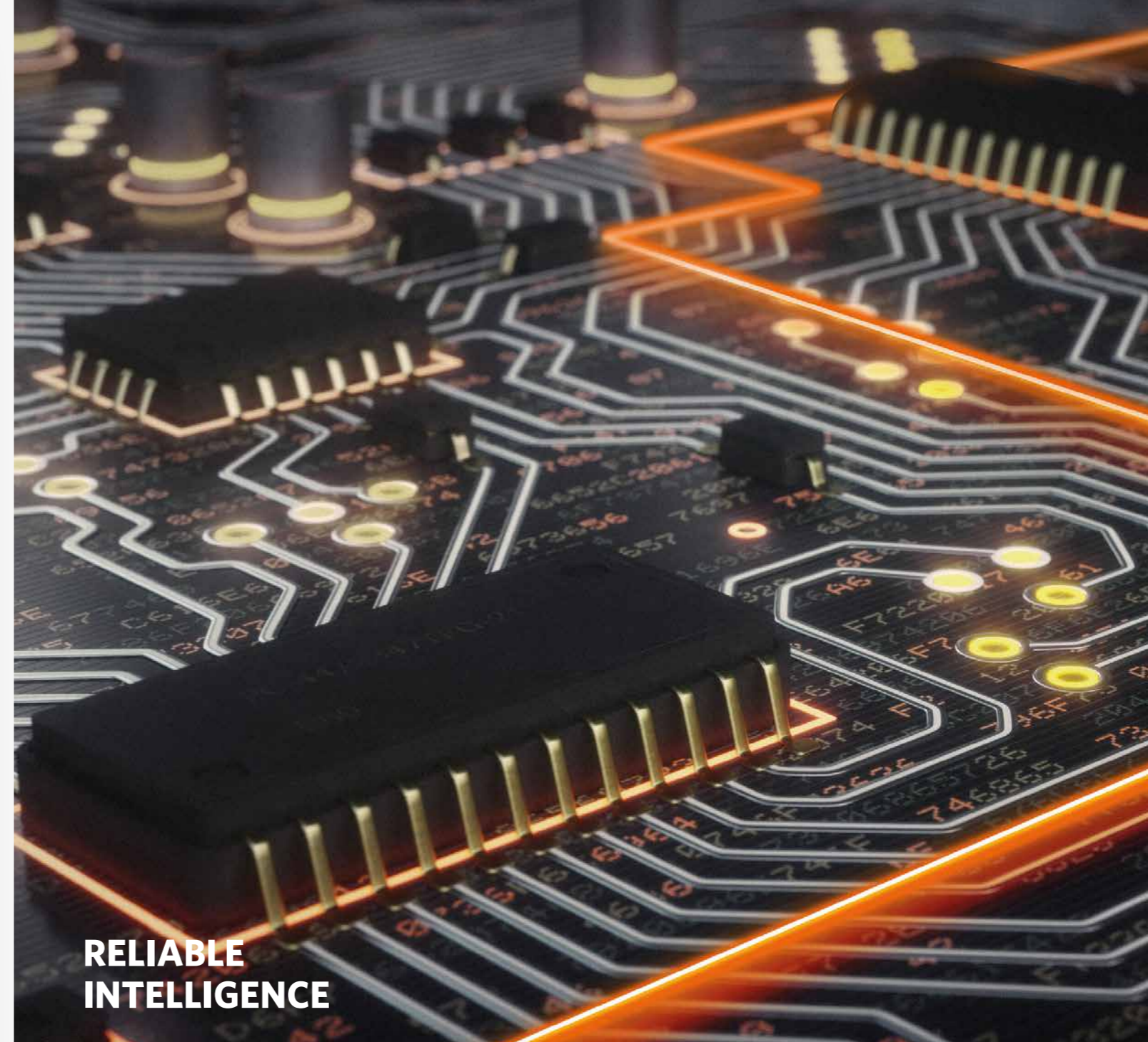

**RELIABLE
INTELLIGENCE**

Project-specific systems

The HITEC PowerPRO3600 can be fully integrated to meet site-specific design requirements. Custom solutions are available to provide:

- Growth scenarios to match capital investment and operational costs with revenues generated
- Custom solutions using proven and tested designs
- Maximum availability of processes to meet industry standards by creating redundancy and eliminating any single points of failure
- Optimal cost control
- Designs in line with the most rigorous operating and maintenance scenarios
- Fast speed of deployment
- Low/medium voltage systems

Total Solution Provider

We promote long-term service partnerships that deliver quality, reliability and value throughout the lifecycle of your equipment. Our customized service solutions encompass an advanced remote monitoring platform, performance reporting, service inspections, maintenance, training and service consultation. Our Helpdesk is dedicated to providing timely, high quality support to all of our customers Worldwide, 24x7x365. We provide the partnership that fits your need and ensures that "Power is in your Control".

